



1-800-443-4859

The Power to Bring People and Places Together !

80/80D Series Installation Guidelines

Warning! A shock hazard or equipment damage may result if improperly installed. Refer installation or servicing to qualified service personnel.

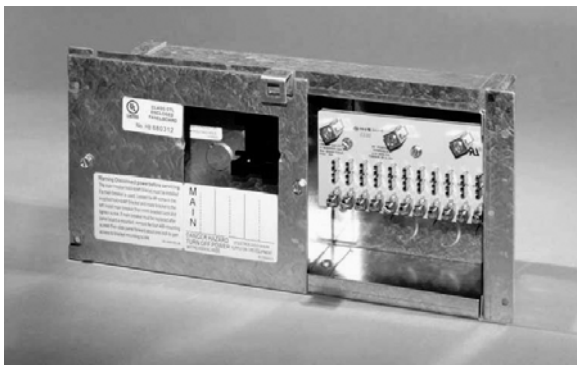

Model 80

(12 Volt cover plate removed)

All information, drawings, flowcharts, and schematics are the property of Parallax Power Supply L.L.C. All rights reserved. **Refer installation and servicing to qualified service personnel.** Service information provided solely for use by Licensed Electricians and Certified RV Technicians. No endorsement of technical expertise, arising from the use of the information supplied is either expressed or implied.



Model 80D

(w/ Decorative Door)

120 VAC Electrical installation shall comply with Article 551 and other applicable sections of the National Electric Code.

12 VDC installation shall comply with ANSI/RVIA 12 V.

Horizontal Mounting Only! Mount the model 80 or 80D Distribution Panel to a vertical surface with the front accessible from the living area of the RV. Leave adequate space behind unit for wire routing.

Panel rated for a main 30 ampere and a maximum of 5 branch circuits. See AC wiring label for list of suitable breakers for main and branch circuits. Use suitable filler plates for any unused breaker locations.

1. Install appropriately sized conduit nipples on all AC or DC Chassis knockouts removed to provide wire support and strain relief.
2. Connect 30 ampere Shore line cord (black) “hot” lead into base of 30 ampere maximum main breaker.
3. **NEC requires breaker “hold-down” bracket to secure 30 ampere “main” breaker.**
4. Shore Line and 120 VAC load circuit (white) Neutrals connect to this isolated terminal bar.
5. Shore Line and 120 VAC load circuit (green) grounds and bonding conductor connect to this terminal bar.
6. AC bond routing hole for (# 8 AWG minimum required) AC bonding conductor.
7. 120 VAC load breakers amperage rating chosen by AWG wire size used for the load. Connect to (black) load circuit “hot” leads. #14 AWG “Romex” connect to maximum 15 ampere load breaker. #12 AWG “Romex” connect to maximum 20 ampere load breaker.

The Power to Bring People and Places Together !

80 Series AC Wiring

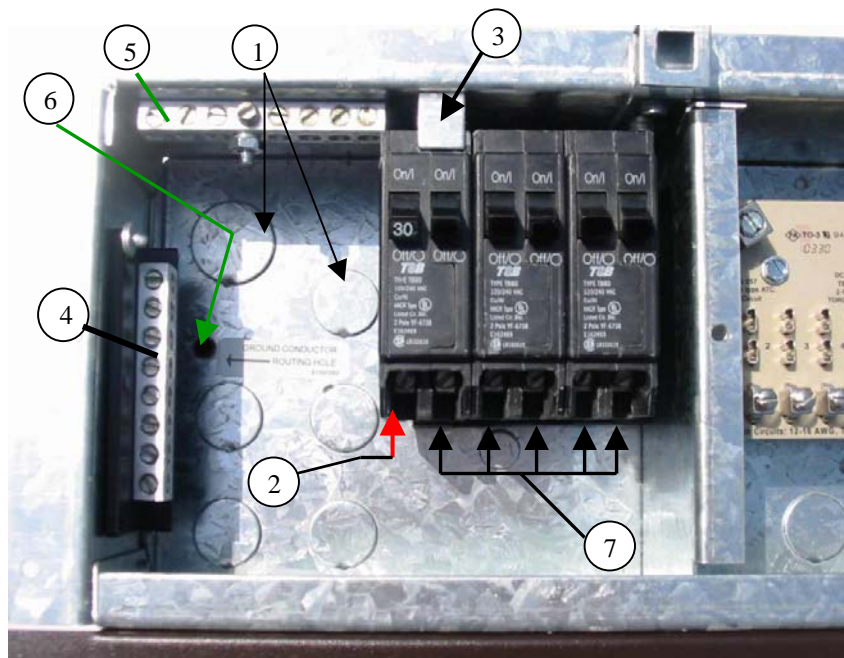

Product shown with dead front plate removed.

***** Note- AC Breakers and DC load fuses not supplied with unit.**

Electrical installation shall comply with Article 551 and other applicable sections of the National Electric Code.

Refer to breakers and wiring labels for terminal torque ratings. .

1-800-443-4859

80 Series AC Wiring Label

120 VAC Wiring Label

(located on back of metal dead front plate covering breaker compartment)

Electrical installation shall comply with Article 551 and other applicable sections of the National Electric Code.

PANELBOARD WIRING DIAGRAM MOUNT PANEL AS SHOWN BELOW

Short circuit rating of this panelboard is 10,000 RMS symmetrical amperes, 120VAC, but the rating is limited to the lowest interrupting capacity at a supply voltage of any breaker installed. The replacement circuit breakers must be of the same type and interrupting ratings.

NOTE: One of the typical diagrams, shown below pertains to this model. Main breaker must be used when 3 or more branch breakers are used. The following breakers are suitable for MAIN and BRANCH breakers:

Bryant - BR, BD, GFCB, Filler Plate-fp-1B
 ITE Gould - QP, QT, Filler Plate-QF3
 Thomas & Betts - TB, TBBD
 Filler Plate - FP-1CTB
 Square D - HOM: Filler Plate-HOMFP
 TORQUE RATINGS: 8-14 AWG - 36 IN. LBS.
 Square D - HOMT: Filler Plate-HOMFP
 TORQUE RATINGS: 8-14 AWG - 26 IN. LBS.

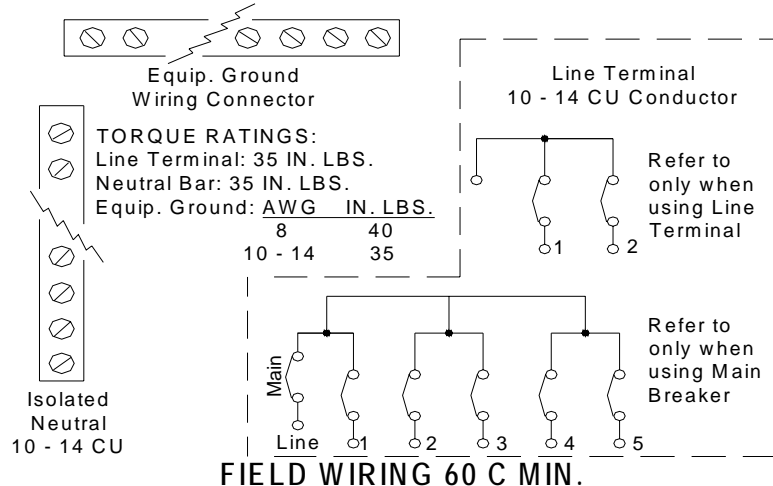

FIELD WIRING 60 C MIN.

When Equipped with " Option A" option, suitable for use in accordance with article 702 of the National Electrical Code, ANSI/NFPA 70.



**PARALLAX
POWER
SUPPLY L.L.C.**

1-800-443-4859

The Power to Bring People and Places Together !

Examples of Listed Circuit Breaker Types

THOMAS & BETTS

Type TBBD Twin Pole-Plug In

Requires One 1" Space

HACR SWD Rated
120/240VAC 10,000 AIC



SIEMENS ITE /GOULD

Type QT Twin Pole-Plug In

Requires One 1" Space

HACR 120/240VAC
10,000 AIC

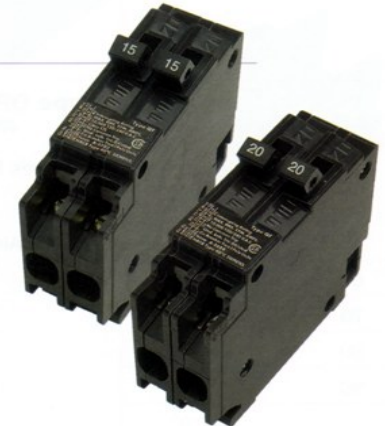

SQUARE D

Type HOMT Twin Pole-Plug In

Requires One 1" Space

HACR 120/240VAC
10,000 AIC



Cutler-Hammer Bryant

Type BD- Type C Twin Pole-Plug In

Requires One 1" Space

HACR SWD Rated
120/240VAC 10,000 AIC





1-800-443-4859

80 Series DC Wiring Label

**12 VDC installation shall
comply with ANSI/RVIA 12 V.**

All information, drawings, flowcharts, and schematics are the property of Parallax Power Supply L.L.C. All rights reserved. Refer installation and servicing to qualified service personnel. Service information provided solely for use by Licensed Electricians and Certified RV Technicians. No endorsement of technical expertise, arising from the use of the information supplied is either expressed or implied.

DC DISTRIBUTION PANEL

REPLACE WITH LITTELFUSE TYPE 257 FUSE. MAX. FUSE SIZE 20A.

- 1 _____ AMP _____
- 2 _____ AMP _____
- 3 _____ AMP _____
- 4 _____ AMP _____
- 5 _____ AMP _____
- 6 _____ AMP _____
- 7 _____ AMP _____
- 8 _____ AMP _____
- 9 _____ AMP _____
- 10 _____ AMP _____
- 11 _____ AMP _____

FUSE DIAGRAM



Use appropriate size wire for feeder terminals and branch circuits.

WIRING INSTRUCTIONS

- A-CONVERTER OUTPUT CKTS 1-11: 12 VDC for RV 12 V Loads. DO NOT USE HIGHER AMP FUSE.
- B-LUG FOR POSITIVE LEAD OF 12 VOLT BATTERY OR CONVERTER.



80 Series DC Wiring

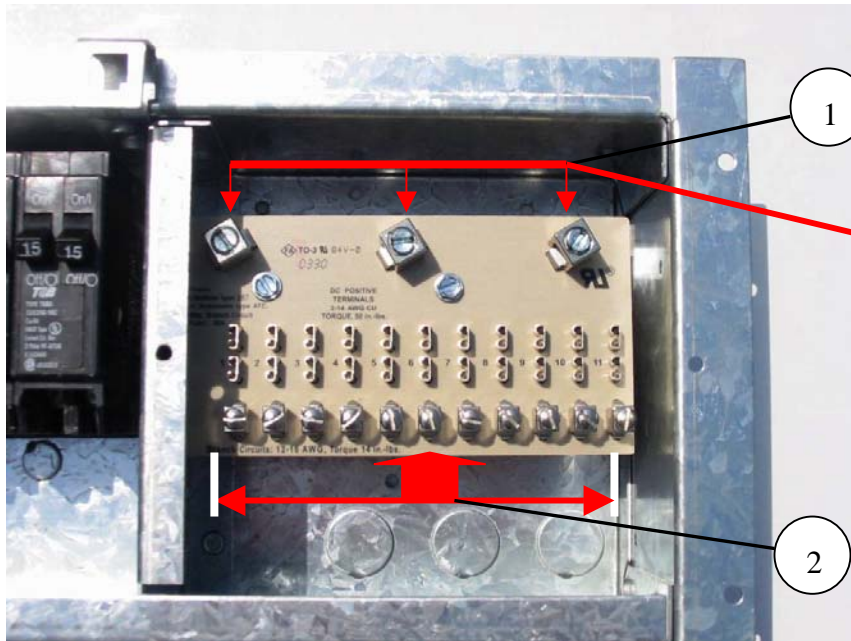

Product shown with Door and/or access covers removed.

12 VDC installation shall comply with
ANSI/RVIA 12 V

All information, drawings, flowcharts, and schematics are the property of Parallax Power Supply L.L.C. All rights reserved. Refer installation and servicing to qualified service personnel. Service information provided solely for use by Licensed Electricians and Certified RV Technicians. No endorsement of technical expertise, arising from the use of the information supplied is either expressed or implied.

Install appropriately sized conduit nipples on all DC Chassis knockouts removed to provide wire support and strain relief.

1. Converter or Battery DC positive input wiring terminals. # 8 AWG CU w/ 90 degree Celsius insulation rating required minimum . Terminals are electrically connected together and may be utilized as desired.
2. 12 Volt Positive load circuit connection terminals. Fuse each load circuit per NEC Code (Table 310-16) appropriate to AWG and temperature rating of conductor used.
3. Connect 12 volt load circuits, battery, and converter negatives to an appropriately rated connection terminal bar. GR series recommended.

