

Model ATS
 Automatic Line/Generator Switch
 Removal Instructions

Warning!!! Possible Shock Hazard Exists!!! Refer installation or servicing to qualified service personnel.

1. **Disconnect all sources of AC or DC power before servicing!**
2. Refer to Figure 1.
3. Remove the 2 - #10 "Dead Front" screws and "Dead Front" plate.
4. Remove ATS output black "hot" wire from base of 30 ampere AC "Main" breaker.
5. Remove ATS output white neutral from the isolated neutral bar.
6. Remove 30 ampere AC "Main" breaker.
7. Remove the 2 - # 8 "Fuse Block" screws and move DC fuse block to gain access behind fuse block.
8. Refer to Fig. 2.
9. Remove the 2 5/16" screws in the indicated locations and slide the ATS away from the chassis.
10. Reverse previous steps to re-install. Make sure no leads have been pinched and that the ATS is tight against the unit.
11. See label inside ATS wiring compartment for proper connection of input "shore line" and generator input wiring.
12. **Torque all wiring connections per specifications on breaker or AC wiring label located on the back of the breaker "Dead Front" plate.**

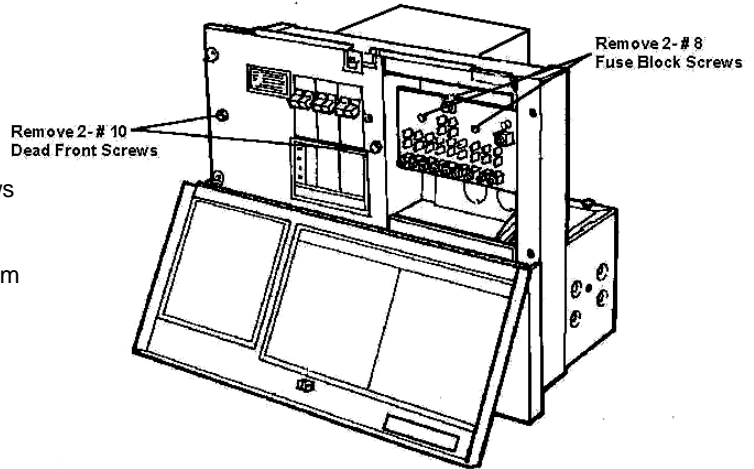

Fig.1

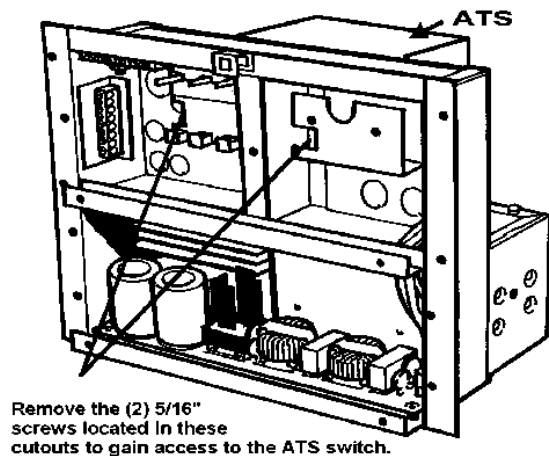

Fig.2