

MOUNTING LOCATION

Qualified service personnel should install the **ATS 5070 series** meeting all applicable codes and standards.

The **ATS 5070** series may be mounted in any position, leaving room for routing shoreline, generator and load conductors. To minimize voltage drop in the wiring the transfer switch should be located as close to the generator and shoreline cord entrance as practical.

DO NOT mount the **ATS 5070 series** in the generator compartment.

The **ATS 5070** series is **not ignition protected**, and therefore should not be mounted in the same compartment as batteries or flammable materials such as gasoline. It may be mounted in the cabin or living area or a basement compartment, but is not suitable for outside locations.

SPECIFICATIONS

**Electrical rating: 120/240 volts AC 60 HZ @ 50amperes.

Maximum generator: 12KW

Enclosure: UL Type 1 16 GA Steel

Listed for US and Canadian applications.

**Note: L1 and L2 rated 35 amperes per leg with 70 ampere neutral when L1 and L2 are in phase. (Optional jumpers must be installed).

Model	Dimensions	Weight
ATS 5070	8"L x 8"W x 4.75" D	7.5 lbs.
ATS 5070 FI	10.25"L x 8.25"W x 5.25" D	10.5 lbs.
ATS 5070 MB	11.25"L x 8.25"W x 5.25"D	9.5 lbs.

Not ignition protected.

Specifications subject to change without prior notice.

WARRANTY STATEMENT

Parallax warrants each **ATS 5070** model to be free from defects in materials and workmanship under normal use and service and limits the remedies to repair or replacement. This warranty extends for two years from the date of purchase and only valid to the original owner and within the continental limits of the United States and Canada. If a problem should occur within the first 24 months of purchase, please contact a dealer that handles warranty service on your Recreational Vehicle.

You may download the entire Parallax Warranty Policy at:
http://www.parallaxpower.com/warranty_policy

No user serviceable parts inside. This warranty does not cover damage due to improper installation, abuse or accidents.



425 Sycamore St. Anderson, IN 46016
Phone: 800-443-4859 Fax: 765-608-5235

For a **special offer** concerning
Extended Warranty Coverage,

Visit our website at www.parallaxpower.com

AUTOMATIC LINE/GENERATOR TRANSFER SWITCH

MODEL ATS 5070 SERIES Operator Guide



ATS 5070 FI
(Flanged Inlet)



ATS 5070 MB
(Mounting Bracket)



ATS 5070



PN # 999-8000-060
Form # 80060 Rev F

INTRODUCTION

Thank you for purchasing a Parallax Power Supply, Model **ATS5070** series automatic Line/ Generator RV transfer switch. We are confident that the **ATS 5070** series model you have purchased will give you outstanding performance for many years. If you have any questions or comments about this product, please contact Parallax's customer service representative at the address or phone and fax numbers listed below.

Parallax Power Supply, L.L.C.
425 Sycamore St.
Anderson, IN 46016
Phone: 800-443-4859
Fax. : 765-608-5235

GENERAL INFORMATION

The **ATS 5070** series is designed to automatically switch the on board 120 or 240-volt appliances to generator power when the generator is activated.

No longer do you need to go outside, remove the shoreline cord from the pole and plug it into the generator receptacle. You simply start the generator and the **ATS5070** will switch the loads for you.

OPERATION

After the **ATS 5070** is installed using one of the typical installations shown in this manual, it will be ready for years of trouble free service. Operation is automatic and is maintenance free.

FROM SHORELINE:

To operate appliances from shoreline power, simply plug in the shoreline cord to the power pole at the campground or dock. The **ATS 5070** automatically connects all AC Appliances to shoreline power.

FROM GENERATOR:

To operate appliances from on board generator simply start the generator. After about a 20 second delay to allow the generator to stabilize the **ATS 5070** will engage, transferring all 120 or 240-volt appliances connected to the **ATS 5070** load terminals to the generator.

AUXILIARY CONTACT OPERATION

The **ATS 5070** series RV line generator switch when connected as in the typical installation **II** shown below may control other equipment in your vehicle. The auxiliary contacts are rated for 50 A @ 120/240 VAC operation and will switch other loads as the **ATS 5070** switches from shore power to generator. These contacts are supplied as non-energized dry contacts.

MODEL 5070 LINE / GENERATOR SWITCH

Typical Installations

Rated - 50A 120/240 Volts 60Hz, Neutral rated 70A with optional jumpers installed.
Auxiliary dry contacts rated 50 A -240 Volts.

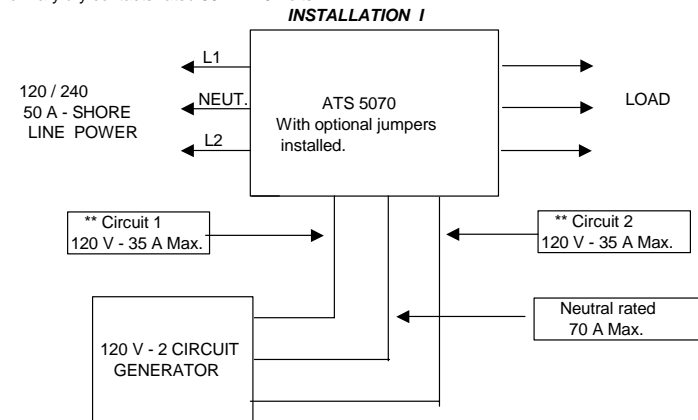

** Note: Circuit1 and Circuit 2 in phase.

